



FOR MEMBERS OF RADIO MANUFACTURERS SERVICE

SERVICE BULLETIN No. 247

Electrical Specifications

Type of Circuit: Superheterodyne. Pentode Power Output.
Power Supply: 115 volts A. C. 50 to 60 or 25 to 40 cycles.
Power Consumption: 65 Watts.
Philco Tubes Used: 2 type 6K7G, R. F. and I. F. Circuit; 1 type 6A8G, Detector Oscillator; 1 type 6Q7G, 2nd Detector, A. V. C., and 1st Audio; 1 type 6F6G, Output and 1 type 5Y4G, Rectifier.
Intermediate Frequency: 470 K. C.
Tuning Ranges: Two. Range 1—530 to 1650 K. C. Range 2—1500 to 3700 K. C.
Speaker: S-16.
Power Output: 3 watts.

Aerial Connections: The Philco ALL Wave Aerial is recommended for use with this receiver, to obtain maximum sensitivity and noise reduction. The red and black leads of the "transmission line" (lead-in) are connected to terminals 1 and 2 respectively on the terminal panel provided at the rear of the chassis. Connect the link provided on the terminal panel across terminals 3 and 4.

If a temporary aerial is used, the link is connected across terminals 2 and 3, the aerial connects to terminal 1.

A good ground connection is desirable in all installations. Make the ground connection from the nearest water or radiator pipe to terminal 3 on the terminal panel.

Adjusting Compensator

To accurately adjust this receiver, precision test equipment is necessary. A signal generator such as the PHILCO MODEL 088 Signal Generator, covering from 110 to 20,000 K. C. is recommended for use in adjusting the compensators at the various frequencies specified. A visual indication of the receiver output is also necessary to obtain correct adjustment of the compensators. PHILCO MODEL 025 Circuit Tester contains a sensitive output meter and is recommended for these adjustments.

Philco Fibre Wrench No. 3164 and Fibre Handle Screw-Driver No. 27-7059 complete the necessary equipment for these adjustments. The locations of the various compensators are shown in Figs. 2 and 3.

The following procedure must be observed in adjusting the compensators:

DIAL ADJUSTMENT—The tuning condenser is set at the maximum capacity position, by turning the tuning knob clockwise. Loosen the set screw of dial hub and set dial, with Glowing Indicator centered between the first and second index lines at the low frequency end of scale.

OUTPUT METER—The 025 Output Meter is connected to the plate and cathode terminals of the 6F6G tube. Adjust the meter to use the (0-30) volt scale.

During the I. F. and R. F. adjustment, the signal generator output should be maintained at the lowest possible level that will give an indication on the output meter.

INTERMEDIATE FREQUENCY CIRCUIT

1. Turn selector switch to range 1 (counter-clockwise). Rotate the tuning control to approximately 600 K. C. Connect the 088 Signal Generator output lead through a .1 mfd. condenser to the grid of the 6A8G tube and the output ground lead to the receiver chassis.
2. Set signal generator dial indicator for 470 K. C. Adjust attenuator for approximately 1/4 scale reading on output meter. Then adjust compensators (20s) 2nd I. F. Sec., (20p) 2nd I. F. Pri., (19s) 1st I. F. Sec., and (19p) 1st I. F. Pri. for maximum reading on output meter.

RADIO FREQUENCY CIRCUIT

Tuning Range 1—530-1650 K. C.

1. Leave selector switch in range 1. Remove the signal generator output lead and .1 mfd. condenser from the grid of the 6A8G tube.

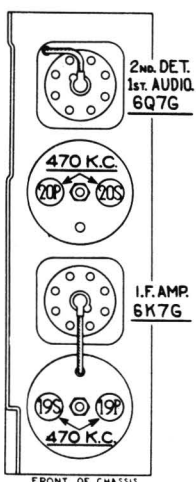

Fig. 2—I. F. Compensator

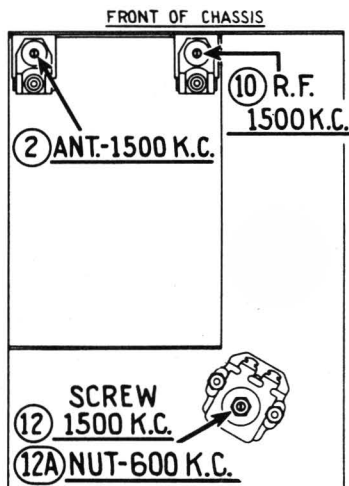

Fig. 3—R. F. Compensators

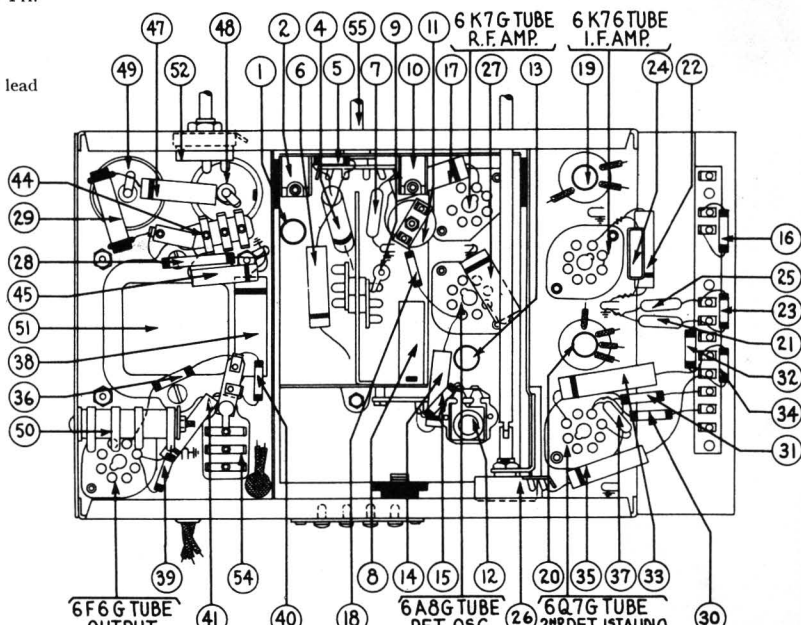

Fig. 4—Base View Chasses

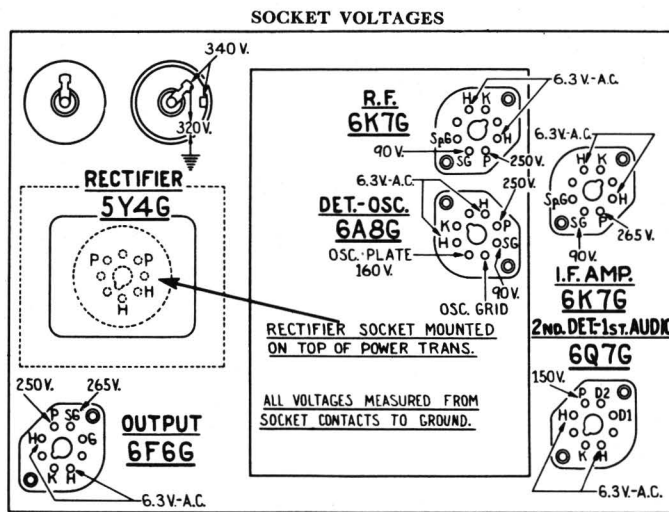

Fig. 1. View of Sockets from Underside Chassis

The voltages indicated by arrows were measured with a Philco 025 Circuit Tester which contains a voltmeter having a resistance of 1000 ohms per volt. Volume Control at minimum, range switch in broadcast position, line voltage 115 A. C.

2. Attach the signal generator output lead through the .1 mfd. condenser to the antenna terminal No. 1 on the aerial panel and the generator ground lead to terminal 3. Connect Terminal No. 2 to ground Terminal No. 3 with connector link provided on the panel.
3. Set signal generator and receiver dials for 1500 K. C. Now adjust compensators (20 Osc. (screw), (20 R. F.), and (20 Ant.) for maximum reading on output meter.
4. The low frequency end of the band is now tuned by turning signal generator and receiver dials to 600 K. C. and adjusting compensator (20a (see note A below) for maximum output.
- (A) When compensator (20a Osc. series (nut) is being adjusted, the tuning condenser must be rolled for maximum output. This is accomplished as follows: First tune compensator (20a for maximum output at 600 K. C. Then vary the tuning condenser back and forth about the 600 K. C. dial mark for the maximum output point. Now retune compensator (20a and again varying the tuning condenser back and forth about 600 K. C. until the maximum output point is reached. This operation of first tuning the compensator, then the tuning condenser is continued until the maximum output is obtained at the 600 K. C. frequency.
5. Turn signal generator and receiver tuning dials to 1500 K. C., then readjust compensators (20s; (20 R. F.); (20 Ant.) for maximum reading on output meter.

Tuning Range 2:

1. The compensating condenser adjustments of Band 1, takes care of Band 2, therefore no compensating condensers are required on the band.

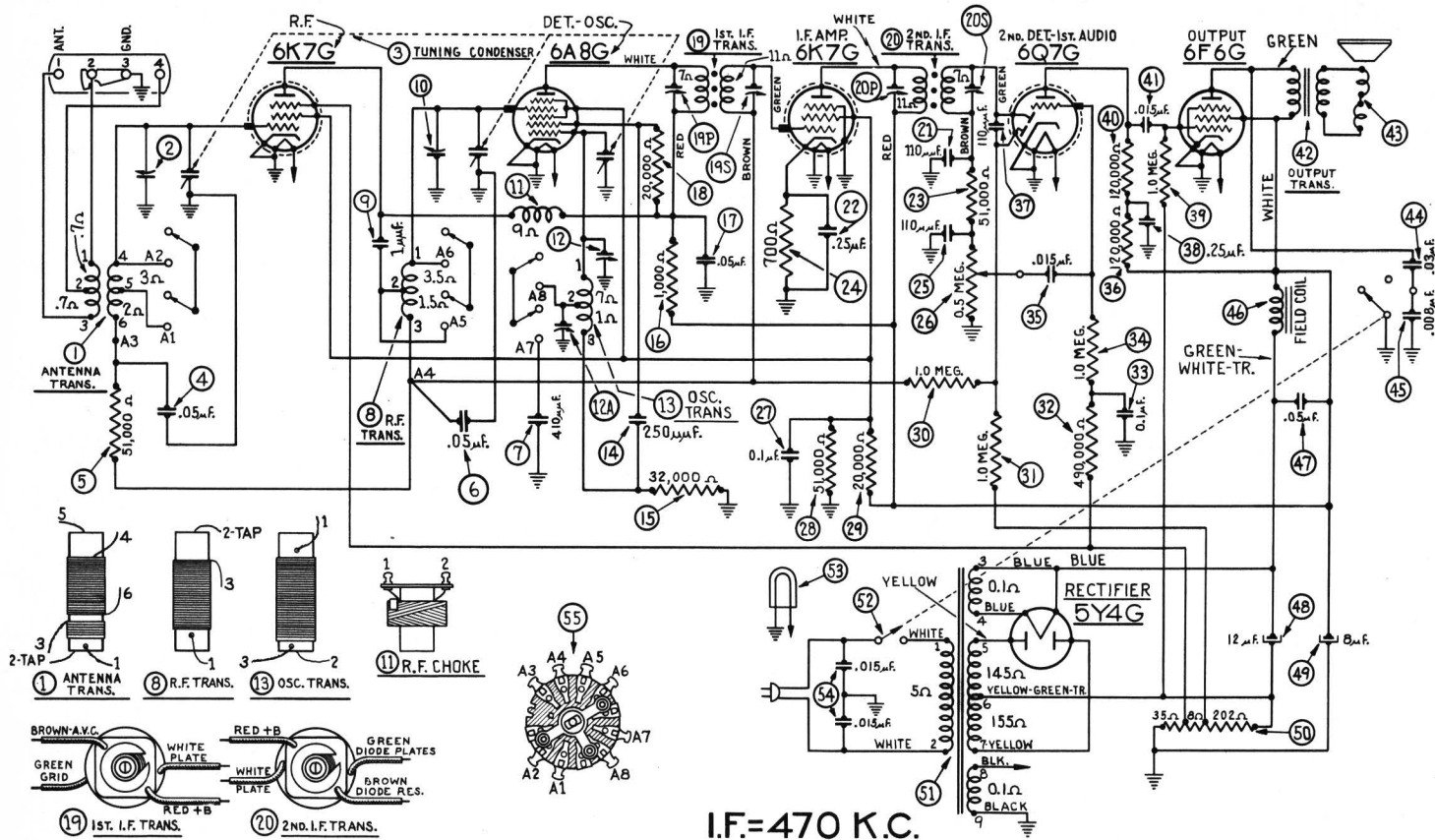

Fig. 5—Schematic Diagram—Model 37-89

Replacement Parts—Model 37-89

Schem. No.	Description	Part No.	List Price	Schem. No.	Description	Part No.	List Price	Schem. No.	Description	Part No.	List Price
1	Antenna Transformer.....	32-2127	\$0.80	35	Condenser (.015 mfd. tubular).....	30-4358	\$0.20		Shaft Spring.....	28-4117	Per C \$0.40
2	Compensator.....	31-6100	.40	36	Resistor (120000 ohms, 1/2 watt).....	33-412339	.20		Washer.....	6717	.02
3	Tuning Condenser.....	31-1833	4.00	37	Condenser (110 mmfd. mica).....	30-1031	.20		Washer.....	4436	Per C 1.50
4	Condenser (.05 mfd. tubular).....	30-4020	.20	38	Condenser (.25 mfd. tubular).....	30-4134	.35		Shaft Retaining Clip.....	28-8610	.03
5	Resistor (51000 ohms 1/2 watt).....	33-351339	.20	39	Resistor (1 megohm, 1/2 watt).....	33-510339	.20		Mtg. Grommet.....	27-4317	.04
6	Condenser (.05 mfd. tubular).....	30-4020	.20	40	Resistor (120000 ohms, 1/2 watt).....	33-412339	.20		Mtg. Washer Sleeve.....	28-2257	.01
7	Condenser (410 mmfd.).....	30-1000	.25	41	Condenser (.015 mfd. tubular).....	30-4226	.20		Mtg. Sleeve Bushing.....	27-8339	Per C .40
8	R. F. Transformer.....	32-2128	.60	42	Output Transformer.....	32-7019	.85		Mtg. Screw.....	W-729	Per C .45
9	Condenser Two Wires Twisted.....			43	Cone & Voice Coil.....	36-3157	.80		Mtg. Washer.....	28-3927	.01
10	Compensator.....	31-6100	.40	44	Condenser (.03 mfd. bakelite).....	8318-SU	.35		R. F. Unit Support.....	28-3856	.10
11	Choke.....	32-2139	.35	45	Condenser (.008 mfd. tubular).....	30-4112	.20		Support Locking Plate.....	28-3975	.01
12	Compensator.....	31-6101	.20	46	Field Coil & Pot Assembly.....	36-3664			Support Locking Plate.....	28-3889	.02
13	Osc. Transformer.....	32-2120	.65	47	Condenser (.05 mfd. tubular).....	30-4020	.20		Screw.....	W-644	Per C 1.50
14	Condenser (250 mmfd. mica).....	30-1032	.20	48	Electrolytic Condenser (12 mfd.).....	30-2117	1.20		Knobs Tuning.....	27-4321	.10
15	Resistor (32,000 ohms 1/2 watt).....	33-351339	.20	49	Electrolytic Condenser (8 mfd.).....	30-2024	1.10		Knob Volume, Waveswitch, Tone.....	27-4332	.10
16	Resistor (1000 ohms, 1/2 watt).....	33-210339	.20	50	Bias Resistor (245 ohms, Taps 35 and 43 ohms).....	33-3277	.20		Baffle Silk Assembly B, Cabinet.....	40-5935	.75
17	Condenser (.05 mfd. tubular).....	30-4123	.20	51	Power Transformer (115 volt, 50 to 60 cycle).....	32-7583	4.25		Baffle Silk Assembly F, Cabinet.....	40-5933	
18	Resistor (20000 ohms, 1/2 watt).....	33-320339	.20						Speaker S-16.....	36-1225	5.75
19	1st I. F. Transformer.....	32-2100	1.50	52	Tone Control & A. C. Switch.....	42-1180	.75		Screw Speaker Mtg.....	W-1604	Per C .50
20	2nd I. F. Transformer.....	32-2102	1.50	53	Pilot Lamp.....	34-2039	.15		Lockwasher Speaker Mtg.....	W-291	Per C .40
21	Condenser (110 mmfd. mica).....	30-1031	.20	54	Condenser (.015, 015 mfd. bakelite).....	3793-DG	.40		Washer Speaker Mtg.....	W-410	Per C .15
22	Condenser (.25 mfd. tubular).....	30-4446	.20	55	Wave Switch.....	42-1194	.60		Nut Speaker Mtg.....	W-124	Per C .35
23	Resistor (51000 ohms, 1/2 watt).....	33-351334	.20		Dial.....	27-5204	.35		Screw Chassis Mtg.....		
24	Resistor (700 ohm, 1/2 watt).....	33-1220	.20		Dial Hub.....	28-7152	.10		Washer Chassis Mtg.....	28-2089	Per C .30
25	Condenser (110 mmfd. mica).....	30-1031	.20		Dial Clamp.....	28-2837	.10		Bezel Frame & Plate.....	40-5938	.10
26	Volume Control.....	33-5157	1.00		Screen Bracket & Screen Assembly.....	31-1878	.25		Bezel Gasket.....	27-8311	.01
27	Condenser (0.1 mfd. tubular).....	30-4455	.25		Screw.....	W-650	Per C .40		Bezel Glass.....	27-8298	.05
28	Resistor (51000 ohms, 1 watt).....	33-351439	.20		Vernier Drive.....	31-1844			Bezel Ring.....	28-3967	.35
29	Resistor (20000 ohms, 2 watt).....	33-320539	.30		Pilot Lamp Assembly.....	38-7706	.35		Bezel Screw.....	W-1644	Per C .50
30	Resistor (1 meg. 1/2 watt).....	33-510339	.20		Insulator Tone Control.....	27-8320	Per C .40		Bottom Shield Plate F, Cabinet.....		
31	Resistor (1 meg. 1/2 watt).....	33-510339	.20		Nut Tone Control.....	W-684	Per C 1.25		I. F. Coil Shield.....	38-7763	.20
32	Resistor (490000 ohms 1/2 watt).....	33-449339	.20		Lock Washer.....	W-1624	Per C .50		Speaker S16 B, F Cabinets.....	36-1225	
33	Condenser (0.1 mfd. tubular).....	30-4122	.20		Volume Control Shaft.....	28-6498	.10				
34	Resistor (1 megohm, 1/2 watt).....	33-510339	.20								

Figures in black type indicate circled figures in base view.